

# AUTO STEERING VALVE

- Up to 250 bar (3626 psi)
- Maximum flow 60 l/min (16 gpm)
- Threaded connections:
  - ISO 1179 (BSPP/Gas)
  - ISO 11926 (UNF)
- Weight : 11.2 kg (24,7 lbs)
- Material: Steel
- Surface treatment: Phosphating



*Specifications are subject to change without notice.*

## ▷ DESCRIPTION

This block can be installed on tractors already in service with any type of hydraulic steering systems (LS dynamic or conventional).

The valve is used to control an engine by directly actuating on the steering cylinders, based on the GPS system data.

The driver chooses between the manual control and an electronically automated GPS System. For enhanced safety, the automatic mode can be overridden by any manual action of the steering.

This block can supply a proportional flow to the steering cylinders. The customer's electronic control system will then allow the setting of GPS guidance for the tractors that have been modified with this installation.

## ▷ OVERALL DIMENSIONS

Millimeter (inches)

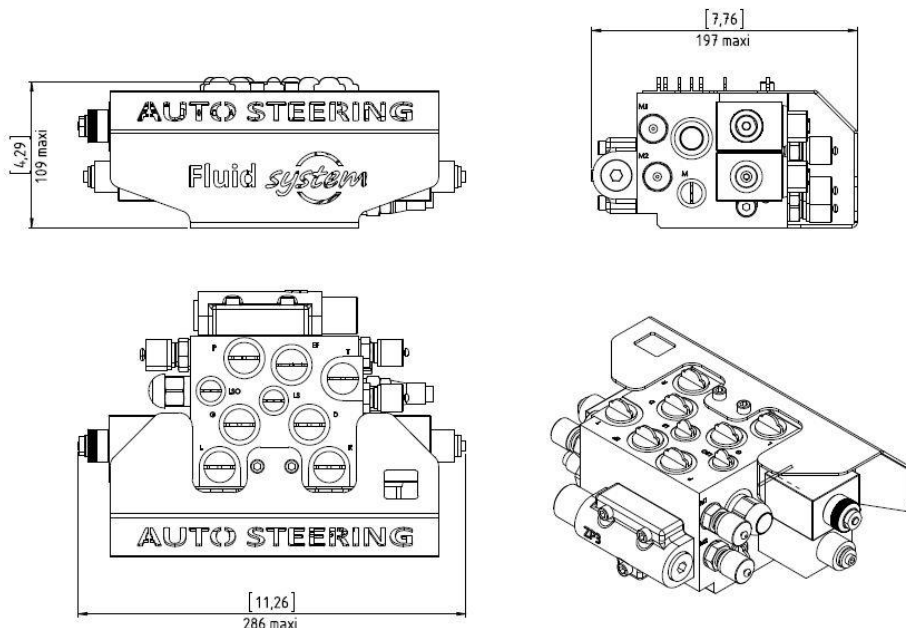

- Security
- Easy to use
- Innovation

▷ HYDRAULIC SCHEMATIC

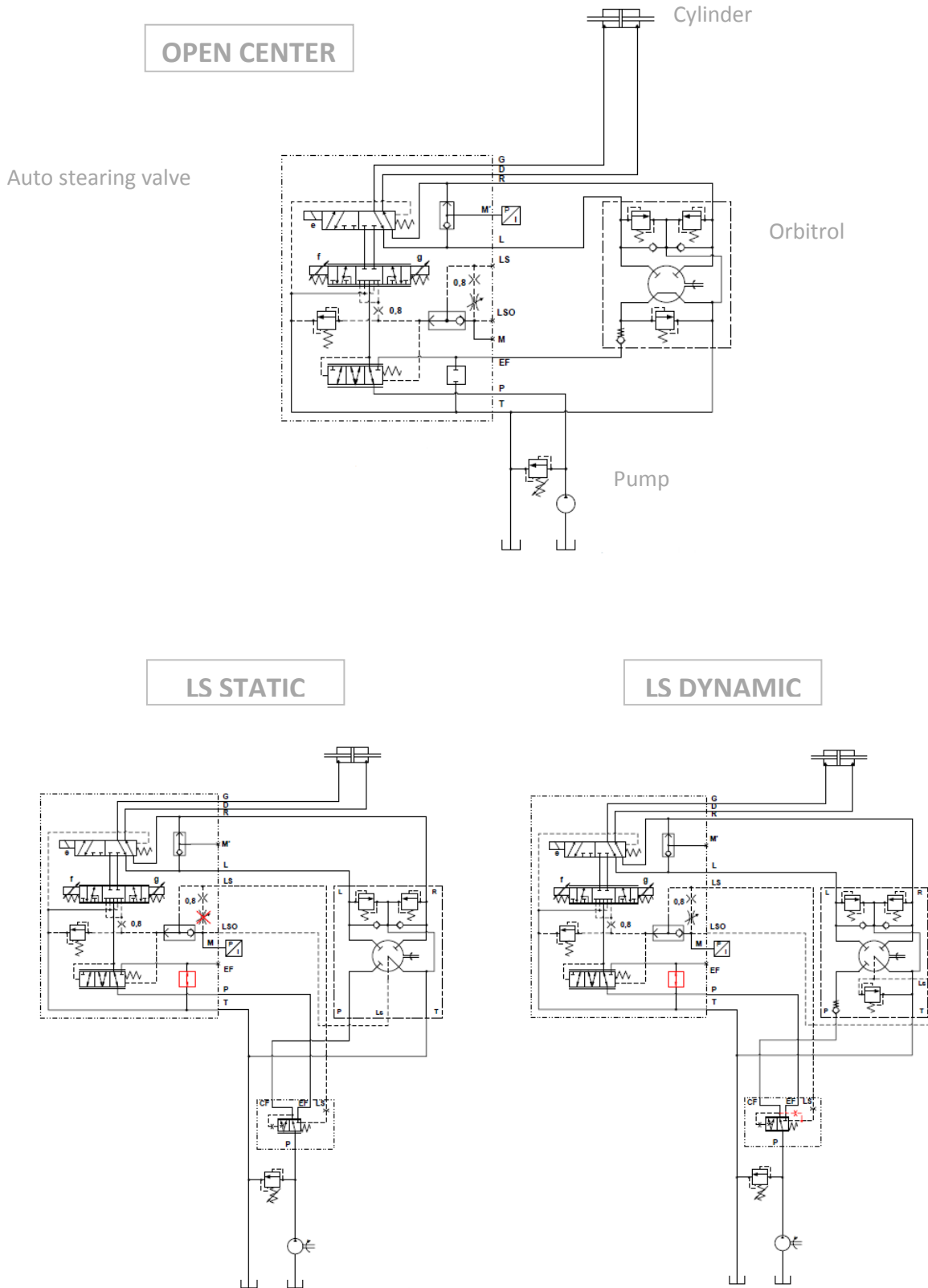

For more details, please contact us to [export@fluid-system.com](mailto:export@fluid-system.com)