

SELECTOR HP 3/2 - CALIBER 35

Specifications are subject to change without notice.

- Up to 500 bar
(7255 psi)
- Up to 500 l/min
(132 gpm)
- Threaded connections:
 - ISO 1179 (BSPP/Gas)
 - ISO 11926 (UNF)
- Surface treatment:
Phosphating

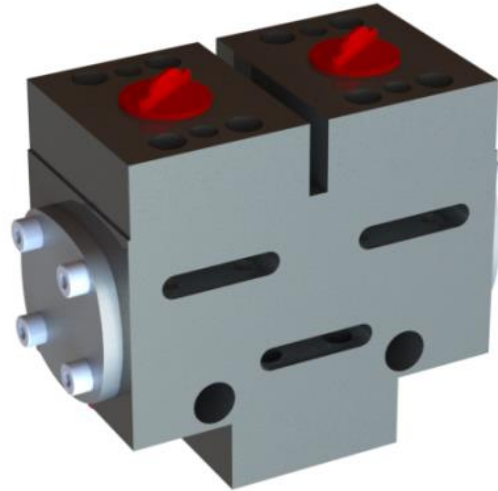

▷ DESCRIPTION

The selector valve, also called directional control valve, is part of the energy transmission chain used to direct the pressurized flow.

It consists of a spool sliding in a cast body to enable communication between outlets. The spool is hydraulically controlled.

▷ APPLICATIONS

Forestry Vehicles

Machine equipped with two transmissions, one hydrostatic for the movement of the machine and another for the tooling operation control (clearing saw, hoist, etc...).

The system equipped with a selector valve requires only one pump to feed:

- 1- The back drive
- 2- The front drive
- 3- The two at the same time

▷ **HYDRAULIC SCHEMATIC**

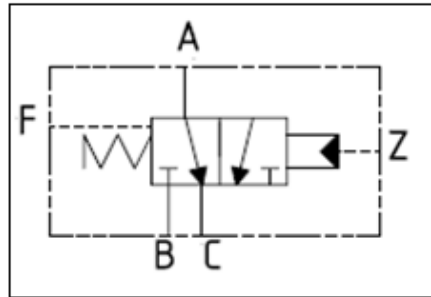

▷ **OVERALL DIMENSIONS**

Millimeter (inches)

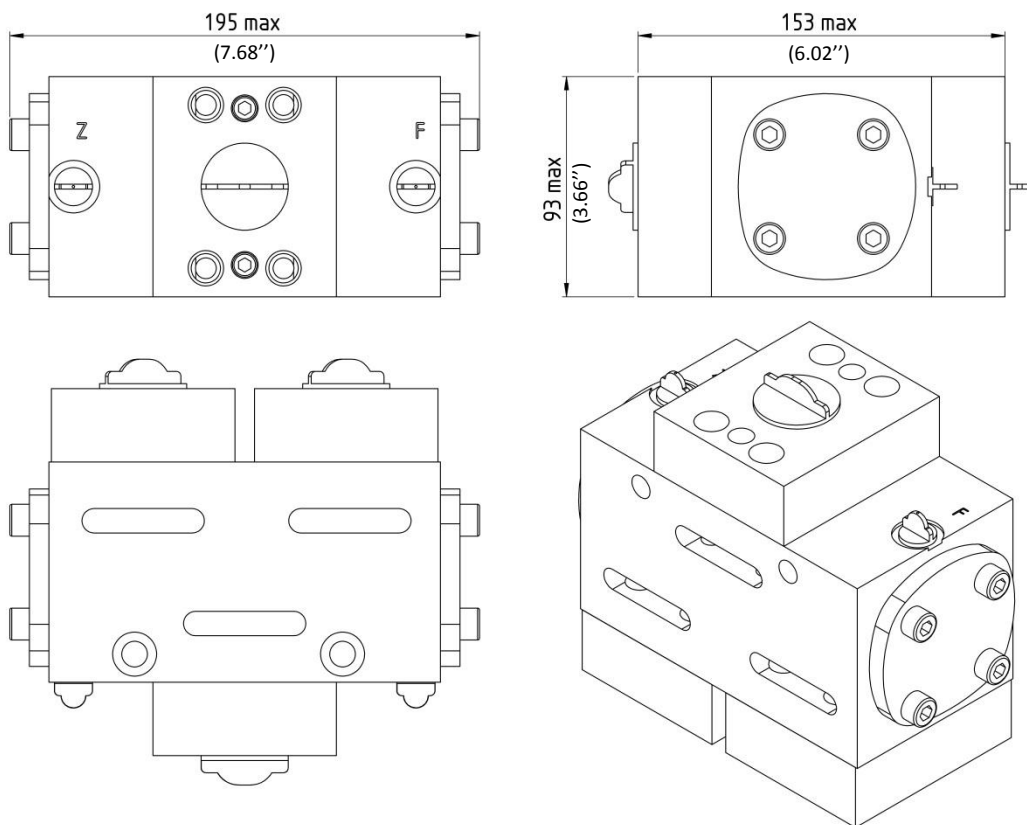

▷ TECHNICAL SPECIFICATIONS

Maximum flow	500 l/min (132 gpm)
Operating pressure	500 bar (7255 psi)
Piloting pressure	Min 8 bar (116 psi) - Max 50 bar (725 psi) *
Maximum pressure	500 bar (7255 psi)
Temperature	- 20°C to 80°C (32°F to 176°F)
Seals	NBR **
Ports / Thread	ISO 1179 (BSP/Gas) - ISO 11926 (UNF)
Weight	12.5 kg (27.6 lbs)
Material	Steel
Viscosity	Between 10 and 100 cSt
Pollution level	20/18/15 as per ISO 4406
Surface treatment	Phosphatation

* Values can be changed upon request to our engineering department.

** Other seals available on demand.

▷ PORT TABLE

PORT	European Norm ISO 1179-1	US Norm ISO 11926-1	Protective Cap
A, B, C	1 1/4" SAE 6000 PSI	1 1/4" SAE 6000 PSI	Plastic
F, Z	1/4" BSP	1/2" -20 UNF-2B	Plastic

▷ SPECIFICATION CURVES

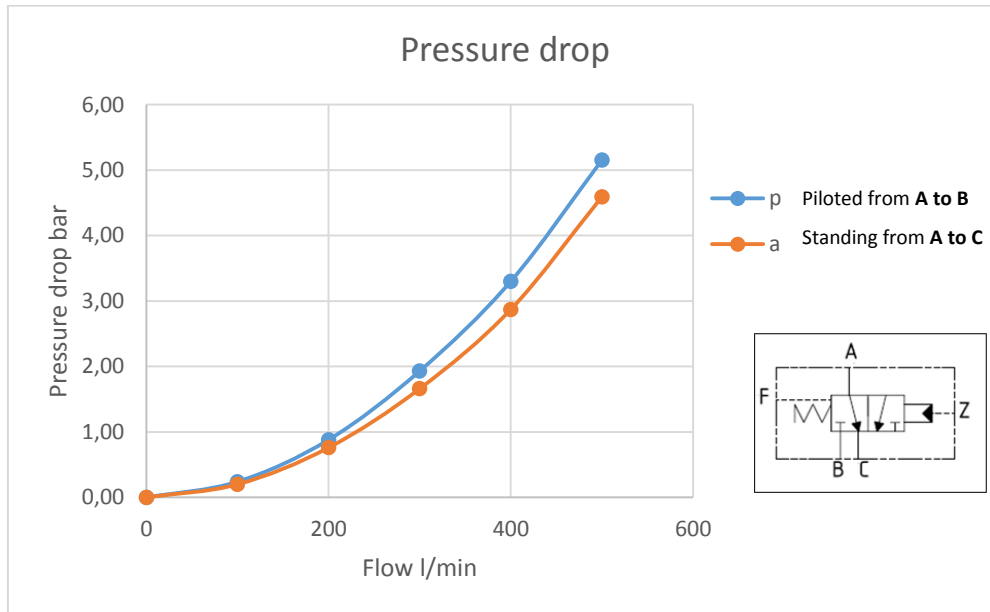

▷ PRODUCT CODE

