

Fluidesign/New Holland Agriculture

LMS Imagine.Lab AMESim used to optimize emergency braking for grape harvesters

Case Study

Industry

Industrial machinery and equipment

Business challenges

Maintain leadership in product innovation

Improve driver safety

Comply with regulations

Keys to success

Ability to investigate various architectures

Simulating dangerous maneuvers

Instant visualization of vehicle dynamic behavior

Results

Cut total project costs by 25 percent

Reduced development timeframe

Optimized braking system

Certified vehicles

“We began using LMS Imagine.Lab AMESim years ago and have now become a preferred partner for industry leaders looking for robust and cutting-edge products optimized by simulation.”

Vincent Moulin
Sales and Marketing Director
Fluidesign



New Holland grape harvester 9060L

Hydraulic systems challenges

Hydraulic systems are crucial elements in the design of the latest technological innovations. Used to solve a wide variety of engineering problems, hydraulic systems support product innovations: for increased comfort in steering systems, eco-friendliness in fuel-injection rails, safety in anti-blocking systems, and performance in heat recovery systems as one of many examples.

As system complexity grows along with embedded electronics, design cycles tend to lengthen and costs increase. The implementation of mechatronic system simulation has now become a standard method to keep these factors under control. Yet this still requires not only software knowledge but also application expertise. “With a strong background in intelligent hydraulic components manufacturing, Fluidesign has embraced the importance of simulation for mastering engineering complexity,” says Vincent Moulin, sales and marketing director, Fluidesign. “We began using LMS Imagine.Lab AMESim years ago and have now become a preferred partner for industry leaders looking for robust and cutting-edge products optimized by simulation.”

That is why New Holland Agriculture (New Holland) turned to Fluidesign to bring innovation to hydraulic systems for its latest

self-propelled grape harvesters. For more than three decades, New Holland has developed machinery specifically designed for vineyards, with such innovations as swinging harvesting heads, the Noria conveying system, the SDC shaking systems and cabs with greater comfort. These innovations have made New Holland’s reputation in terms of quality, safety, performance and efficiency. Its machines have been widely acclaimed, making New Holland the undisputed market leader.

European regulations on reducing pollutant emissions have become all-encompassing, concerning every vehicle with an internal combustion engine. Grape harvesters are no exception and must comply with these standards, which are spurring the implementation of new engine technologies, such as exhaust gas recirculation and selective catalytic reduction. However, reducing emissions leads to additional costs and weight.

With these issues in mind, one solution is to increase the use rates of grape harvesters. The less time spent transporting a machine to and from a grapevine, the more profitable the machine becomes. That is why harvesters have been equipped with more powerful engines, to reach work fields faster and optimize usage time.

“Using LMS Imagine.Lab has enabled New Holland to rapidly identify different load and torque transfer rates. With these data in mind, we have run the modeling and simulation of vehicles, integrating different new valves; and adjustments have been made to distribute torque and loads, then optimize the braking.”

Frederic Lagors
 Technical Director
 Fluidesign

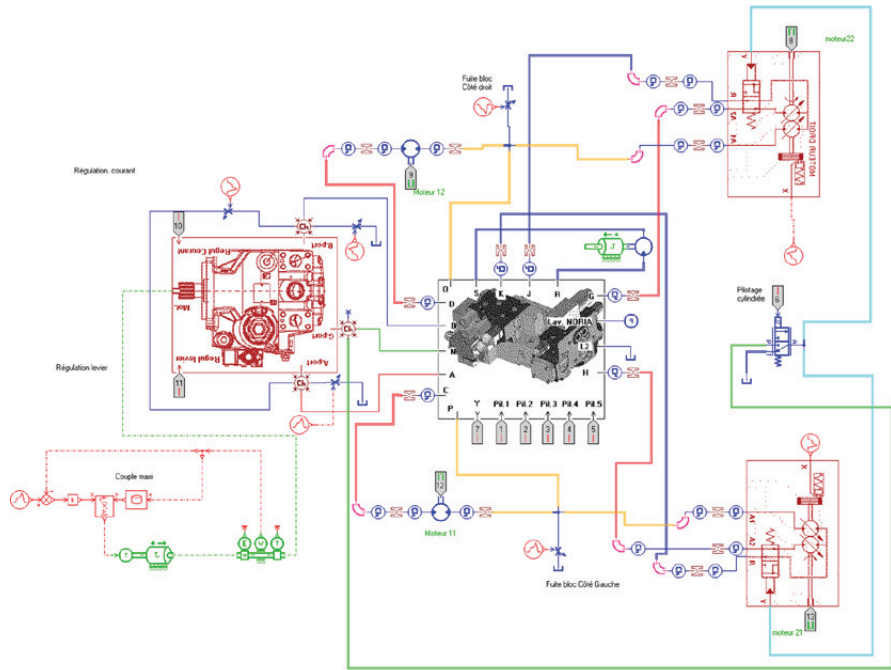

Detail of the hydraulic block model, depicting the different functions: hydraulic power generation, distribution and power delivery to the wheels

Driving on tarred roads also comes with strict safety regulations, especially on braking distance. Regulations on emergency braking define specific braking distance and clear certification criteria. As the total weight of harvesting machinery increases, those requirements are becoming more and more difficult to reach. Not to mention that a failure to comply with the regulations can be very costly not only in terms of fines and penalties, but also in lost market share.

This is why New Holland entrusted Fluidesign to come up with a technological solution that will enable New Holland to comply with regulations for their VN9040-type grape harvester.

Modeling the entire chassis

To assess the dynamic behavior and evaluate the impact of valve design on emergency braking, Fluidesign uses LMS Imagine.Lab AMESim, the de-facto standard for physical simulation of mechatronic systems. Its engineers modeled the complete chassis system – including the chassis and tire contact patch on a 3D road surface, together with the hydrostatic transmission – using off-the-shelf LMS Imagine.Lab AMESim libraries, including hydraulic, hydraulic component design, hydraulic resistance and vehicle dynamics.

Investigating the dynamics and response time of the different elements of the transmission system, such as the hydraulic control of the variable displacement pump, was essential for this study. After model calibration based on measurements, the study focused on the impact of various hydraulic and control parameters for emergency braking. “Using LMS Imagine.Lab has enabled New Holland to rapidly identify different load and torque transfer rates,” says Frederic Lagors, Fluidesign’s technical director. “With these data in mind, we have run the modeling and simulation of vehicles, integrating different new valves; and adjustments have been made to distribute torque and loads, then optimize the braking.”

The use of AMESim enabled Fluidesign to validate the architectural choices and launch the industrialization of the hydraulic valve of the hydrostatic circuit. This virtual study allowed New Holland to identify the ideal set of parameters to reach their optimum braking objectives. Moreover, it has enabled the company to design a special braking assistance valve to be implemented where it is most efficient in the hydraulic circuit for optimized emergency braking. This hydraulic flow control valve is actuated – only in case of an emergency – using a control unit.

“The AMESim 3D animation tool provided the ability to visualize the results as if engineers were watching the real machine and to get the most out of the powerful analysis tools”

Frederic Lagors
 Technical Director
 Fluidesign

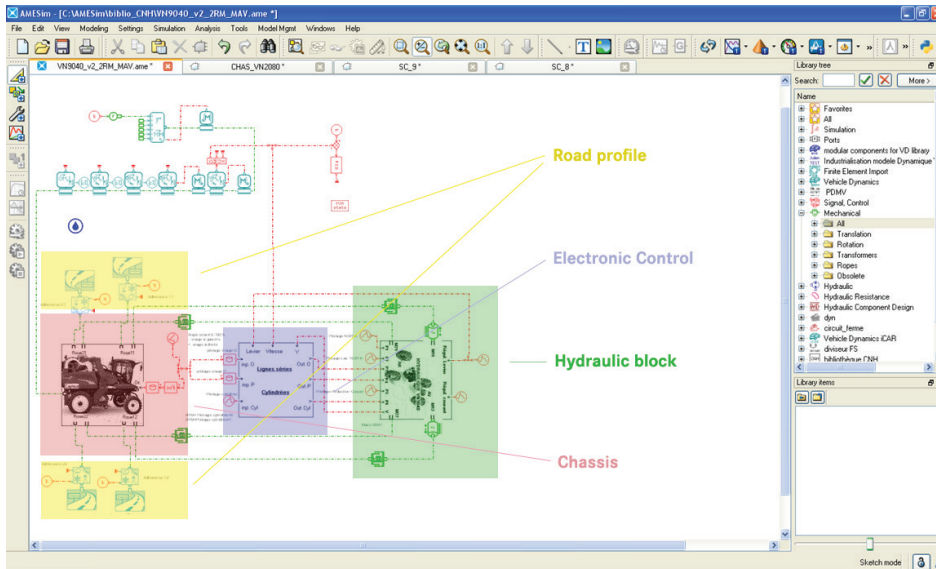

Model of the complete grape harvester including the hydraulic block, the electronic control, the chassis and the road profile

An instant insight into what works best

“The AMESim 3D animation tool provided the ability to visualize the results as if engineers were watching the real machine and to get the most out of the powerful analysis tools,” says Lagors. “This capability gives results a particular and immediate meaning, as a perfect complement to plots and graphs. Different product configurations can then be rapidly tested virtually to select the more relevant ones for deeper insights.”

Using LMS Imagine.Lab AMESim enabled Fluidesign to better understand the physics of the complete chassis of the grape harvester and to identify the most important parts of the hydraulic circuit impacting emergency braking. Engineers were able to get a detailed understanding and precise observation of hydraulics phenomena such as flow, pressures and time response that are usually difficult to gauge directly on the machine, but that enable the design of relevant solutions. “The required solution is technically simple most of the time,” says Moulin. “When it is not simple, the software enables engineers to identify the causes of a problem. That’s what AMESim is best at – helping engineers focus on their expertise, not on tools.”

As a consequence, it has been possible to virtually evaluate worst-case scenarios and extreme conditions, which wouldn’t have been the case with real-life testing. This is a major enhancement in safety optimization.

“Using AMESim has been a real asset and enabled New Holland to save several months of engineering studies as they worked on this safety optimization project,” says Lagors.

To detect the root cause of problems or to investigate engineering solutions, grape growers usually proceed with the more traditional method of making real-life measurements in the yard. But this can be costly in terms of transportation expenses for the harvester, engineering fees and testing materials. Plus, the results are uncertain. Pioneering the use of mechatronic system simulation, New Holland decided to invest in Fluidesign’s components and software expertise to streamline the development process.



“The required solution is technically simple most of the time. When it is not simple, the software enables engineers to identify the causes of a problem. That’s what AMESim is best at – helping engineers focus on their expertise – not on tools.”

Vincent Moulin
Sales and Marketing Director
Fluidesign

“Using AMESim has been a real asset and enabled New Holland to save several months of engineering studies as they worked on this safety optimization project.”

Frederic Lagors
Technical Director
Fluidesign

Solutions/Services

LMS Imagine.Lab AMESim

Customer's primary business

Founded in 1984, FLUIDESIGN is a designer and manufacturer of hydraulic, electronic and mechatronic assemblies. Its activities comprise two complementary businesses, which share the same ethos, one producing hydraulic components and the other electronic assemblies.

www.fluidesign.eu/en

New Holland manufactures agricultural machinery, including tractors and equipment for hay and foraging, harvesting, crop production and materials handling. Innovation is at the hearth of its strategic agenda, while continuously finding better, smarter and faster ways to make technology simple, accessible and easy to use.

agriculture.newholland.com

Customer location

Lorette
France

LMS International

Researchpark Haasrode 1237
Interleuvenlaan 68,
B-3001 Leuven [Belgium]
T +32 16 384 200
F +32 16 384 350
info@lmsintl.com

www.lmsintl.com

Total project costs have been cut by 25 percent and more importantly, a robust solution has been found. Embedding its grape harvesters with the safest technology for emergency braking helps position New Holland as a technical leader in the domain. Providing customers with simple but efficient machines has always been New Holland's mission, and the association with Fluidesign and AMESim has helped the company find smarter, better and faster ways to make technology simple, accessible and easy-to-use.

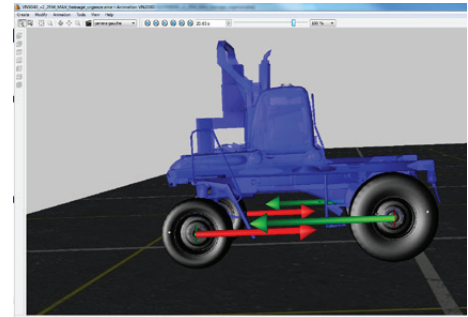

Emergency braking

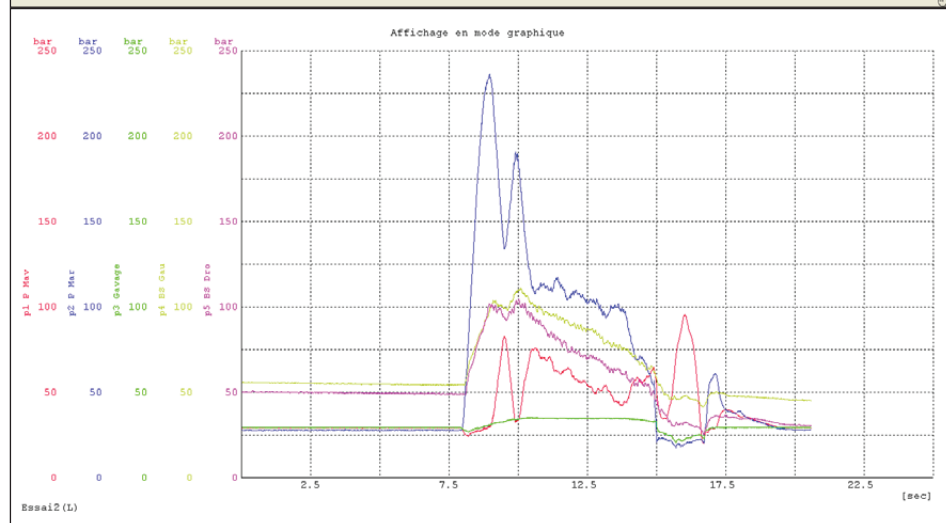
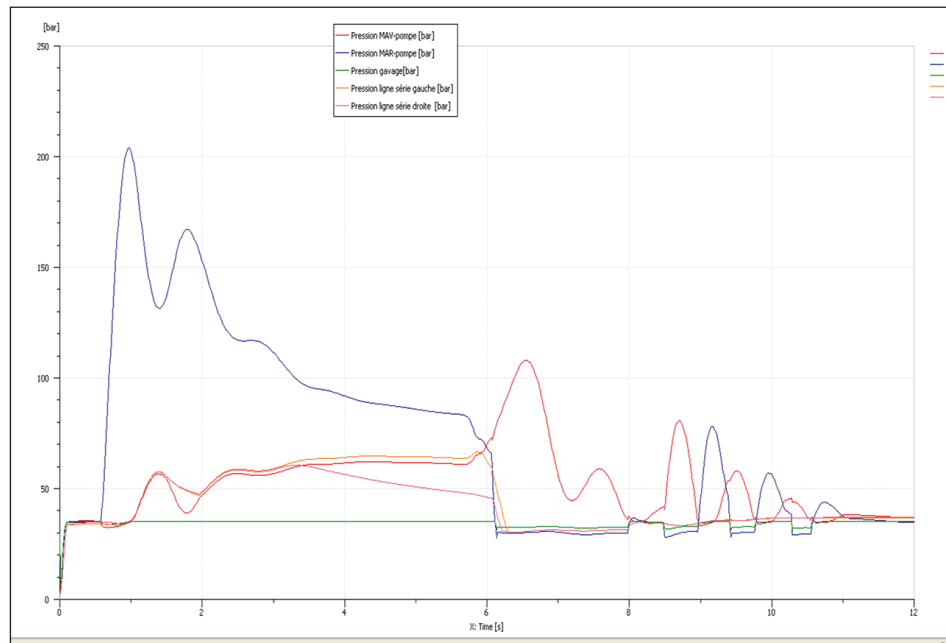

Pressures simulated and experimental results in various part of the circuit during a braking manoeuver, showing the predictability of the numerical model

LMS01 60039 10/13 H - © LMS 2013

All rights reserved. The material presented here is a summary in nature, subject to change, and intended for general information only. Additional details and technical specifications are available on www.lmsintl.com. All trademarks, registered trademarks or product names mentioned in this publication are trademarks or registered trademarks of LMS International or any of its affiliates. All other trademarks are acknowledged.